

Front view and mounting

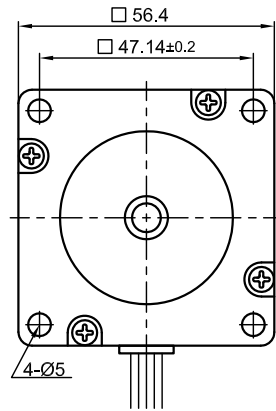

Side view

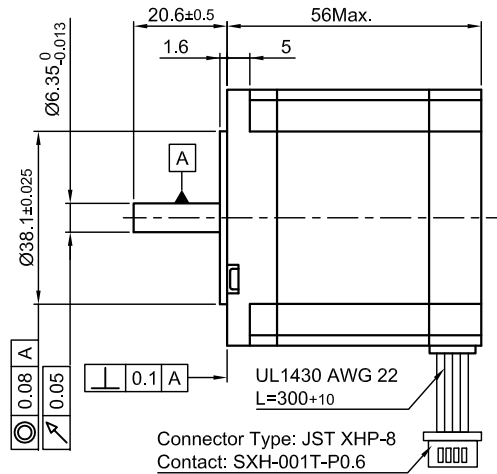

Rear view

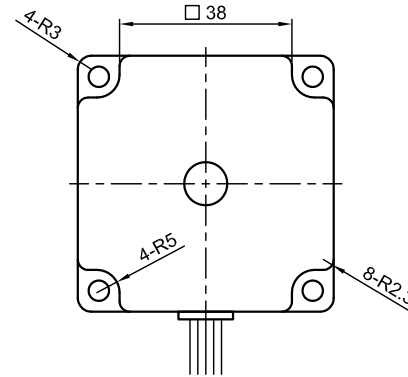

SPECIFICATION	CONNECTION	UNIPOLAR OR BIPOLAR-1 WINDING		BIPOLAR	
		BIPOLAR-1 WINDING	SERIAL	PARALLEL	PARALLEL
VOLTAGE (VDC)		3.4			
AMPS/PHASE		2.0	1.41	2.82	
RESISTANCE/PHASE (Ohms)@25°C		1.7 ± 10%	3.4 ± 10%	0.85 ± 10%	
INDUCTANCE/PHASE (mH) @1KHz		2.5 ± 20% Δ	10.0 ± 20% Δ	2.5 ± 20% Δ	
HOLDING TORQUE (Nm) [lb-in]		0.88 [7.8] Δ	1.24 [10.98] Δ	1.24 [10.98] Δ	
DETENT TORQUE (Nm) [lb-in]		0.04 [0.354]			
STEP ANGLE (°)		1.8			
ACCURACY(NON-ACCUM)		±5%			
ROTOR INERTIA (Kg-m ²) [lb-in ²]		3.0 × 10 ⁻⁵ [0.102]			
WEIGHT (Kg) [lb]		0.7 [1.54]			

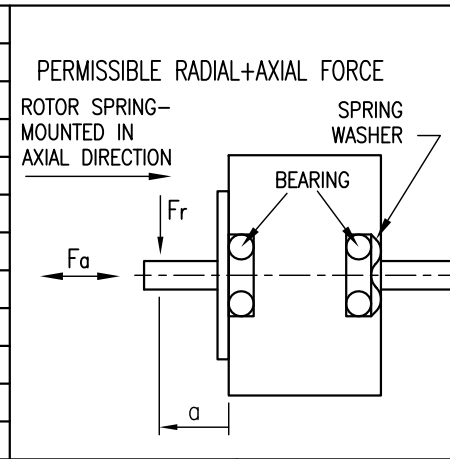

TYPE OF CONNECTION (EXTERN)				MOTOR		
UNIPOLAR	BIPOLAR			CONNECTOR PIN NO.	LEADS	WINDING
	TWINDING	SERIAL	PARALLEL			
A	A	A	A	1	BLK	A
COM	A			3	BLK/WHT	
A\	A	A\	A\	2	GRN/WHT	A\
B	B	B	B	4	GRN	B
COM	B			5	RED	
B\	B	B\	B\	7	RED/WHT	B\
				6	BLU/WHT	
				8	BLU	

FULL STEP 2 PHASE-Ex., WHEN FACING MOUNTING END (X)

STEP	A	B	A\	B\	CCW	CW
1	+	+	-	-		
2	-	+	+	-		
3	-	-	+	+		
4	+	-	-	+		

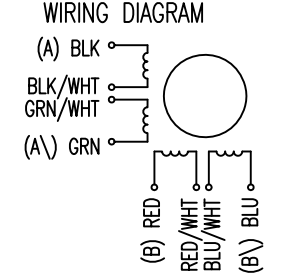

TEMPERATURE RISE: MAX.80°C (MOTOR STANDSTILL; FOR 2 PHASE ENERGIZED)	AXIAL-FORCE Fa (N)	Fa=15
AMBIENT TEMPERATURE -10~ 50°C [14°F ~ 122°F]	DISTANCE a (mm)	5 10 15 20
INSULATION RESISTANCE 100 MOhm (UNDER NORMAL TEMPERATURE AND HUMIDITY)	RADIAL-FORCE Fr (N)	130 90 70 52
INSULATION CLASS B 130° [266°F]		AXIAL RADIAL
DIELECTRIC STRENGTH 500VAC FOR 1 MIN. (BETWEEN THE MOTOR COILS AND THE MOTOR CASE)	SHAFT PLAY (mm)	0.08 0.02
AMBIENT HUMIDITY MAX. 85% (NO CONDENSATION)	AT LOAD MAX: (N)	4.5 4.5

6	HOLD.TOR.+DELE. BACK-EMF	18.10.13	J.D.
5	NEW VALUE OF IND.	18.10.13	J.D.
4	NEW VALUE OF BACK-EMF	20.05.11	J.W.
REV	DESCRIPTION	DATE	APVD

Nanotec
PLUG & DRIVE
ST5918M2008-A

SCALE FREE	APVD	<i>S.Ha.</i>	19.03.07
X ±0.5	CHKD		
1PL ±0.2	DRN	<i>J.W.</i>	21.11.06
2PL ±0.1	SIGNATURE		DATE
ANGLE ±30'			

STEPPING MOTOR
DWG.NO ST5918M2008-A